

Please check the examination details below before entering your candidate information

Candidate surname

Other names

**Pearson Edexcel
International GCSE**

Centre Number

--	--	--	--	--

Candidate Number

--	--	--	--	--

Time 1 hour 30 minutes

**Paper
reference**

4MB1/01

**Mathematics B
PAPER 1**



You must have: Ruler graduated in centimetres and millimetres, protractor, pair of compasses, pen, HB pencil, eraser, calculator. Tracing paper may be used.

Total Marks

Instructions

- Use **black** ink or ball-point pen.
- **Fill in the boxes** at the top of this page with your name, centre number and candidate number.
- Answer **all** questions.
- Answer the questions in the spaces provided
– *there may be more space than you need.*
- **Calculators may be used.**

Information

- The total mark for this paper is 100.
- The marks for **each** question are shown in brackets
– *use this as a guide as to how much time to spend on each question.*

Advice

- Read each question carefully before you start to answer it.
- Check your answers if you have time at the end.
- Without sufficient working, correct answers may be awarded no marks.
- Good luck with your examination.

Turn over ►

P66021RA

©2021 Pearson Education Ltd.

1/1/1/1



P 6 6 0 2 1 R A 0 1 2 8



Pearson

Answer ALL TWENTY NINE questions.

Write your answers in the spaces provided.

You must write down all the stages in your working.

1

ANGLES

Write down all the letters of the above word that have

(a) exactly **one** line of symmetry,

.....
(1)

(b) rotational symmetry of order 2

.....
(1)

(Total for Question 1 is 2 marks)

2 Show that

$$1\frac{1}{3} \times 2\frac{2}{5} = 3\frac{1}{5}$$

Show your working clearly.

(Total for Question 2 is 2 marks)

DO NOT WRITE IN THIS AREA

DO NOT WRITE IN THIS AREA

DO NOT WRITE IN THIS AREA



DO NOT WRITE IN THIS AREA

DO NOT WRITE IN THIS AREA

DO NOT WRITE IN THIS AREA

3 The n th term of a sequence is $3n^2 + 2$

Calculate the sum of the 4th term and the 5th term of the sequence.

.....
(Total for Question 3 is 2 marks)

4 Using ruler and compasses only and **showing all your construction lines**, construct the bisector of angle PQR .

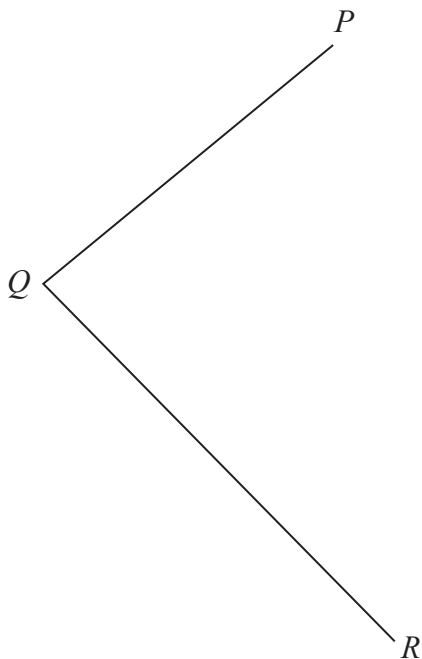

(Total for Question 4 is 2 marks)



- 5 Find the Highest Common Factor (HCF) of 216 and 540
You must show all your working.

.....
(Total for Question 5 is 2 marks)

- 6 Given that $y = 3x^6 - \frac{4}{x^3}$

find $\frac{dy}{dx}$

$\frac{dy}{dx} =$

(Total for Question 6 is 2 marks)

DO NOT WRITE IN THIS AREA

DO NOT WRITE IN THIS AREA

DO NOT WRITE IN THIS AREA



7

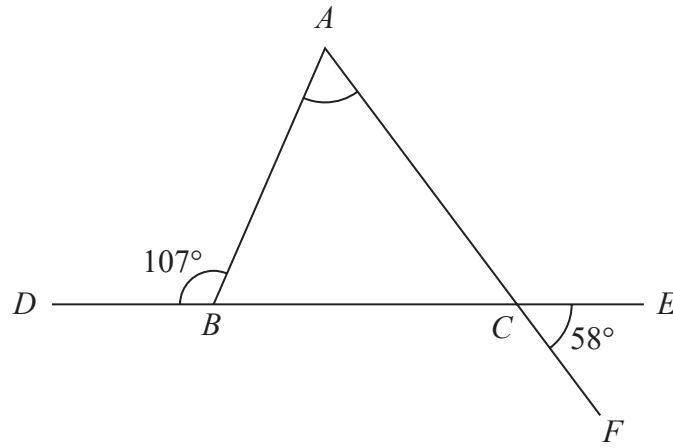

Diagram **NOT** accurately drawn

The diagram shows $\triangle ABC$.

$DBCE$ and ACF are straight lines such that

$$\angle ABD = 107^\circ \text{ and } \angle ECF = 58^\circ$$

Calculate the size, in degrees, of $\angle BAC$.

$$\angle BAC = \dots\dots\dots^\circ$$

(Total for Question 7 is 2 marks)

DO NOT WRITE IN THIS AREA



8 $p, q, 17$ and r are four integers such that $p < q < 17 < r$ and $r = p + 18$

The median of $p, q, 17$ and r is 13

The mean of $p, q, 17$ and r is 15

Find the value of p , the value of q and the value of r .

$p =$

$q =$

$r =$

(Total for Question 8 is 3 marks)

DO NOT WRITE IN THIS AREA

DO NOT WRITE IN THIS AREA

DO NOT WRITE IN THIS AREA



9 The straight line **L** is drawn on the grid.

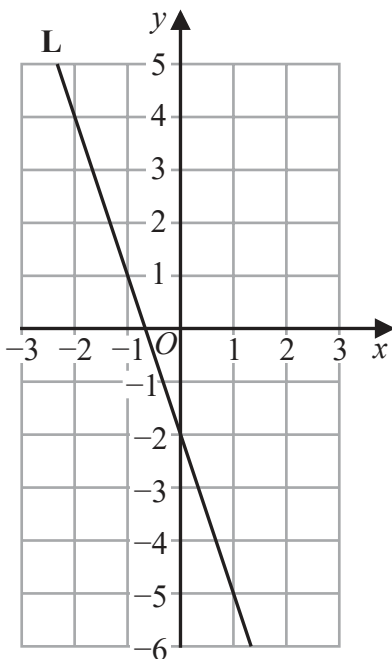

Find an equation for **L**.

.....
(Total for Question 9 is 3 marks)



10 (a) Write 1.2×10^{-4} as an ordinary number.

.....
(1)

(b) Calculate $\frac{6 \times 10^{144} + 5 \times 10^{142}}{5 \times 10^5}$

Give your answer in standard form.

.....
(2)

(Total for Question 10 is 3 marks)

DO NOT WRITE IN THIS AREA

DO NOT WRITE IN THIS AREA

DO NOT WRITE IN THIS AREA



DO NOT WRITE IN THIS AREA

DO NOT WRITE IN THIS AREA

DO NOT WRITE IN THIS AREA

11 A triangle has sides of length 8 cm, 10 cm and 15 cm.

Calculate the size, in degrees to one decimal place, of the smallest angle of the triangle.

○

(Total for Question 11 is 3 marks)



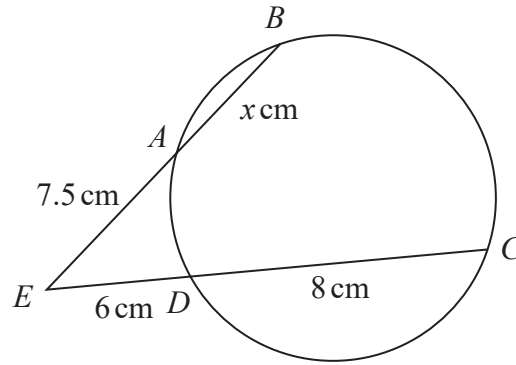

Diagram **NOT** accurately drawn

A, B, C and D are points on a circle.

EAB and EDC are straight lines.

$ED = 6 \text{ cm}$ $DC = 8 \text{ cm}$ $EA = 7.5 \text{ cm}$ $AB = x \text{ cm}$

Calculate the value of x .

$x = \dots\dots\dots$

(Total for Question 12 is 3 marks)

DO NOT WRITE IN THIS AREA

DO NOT WRITE IN THIS AREA

DO NOT WRITE IN THIS AREA



DO NOT WRITE IN THIS AREA

DO NOT WRITE IN THIS AREA

DO NOT WRITE IN THIS AREA

13 Without using a calculator, and showing all your working, express

$$\frac{\sqrt{75} + \sqrt{243}}{\sqrt{7}}$$

in the form \sqrt{a} where a is a positive integer.
Show your working clearly.

.....
(Total for Question 13 is 3 marks)



14 For all values of x ,

$$15 - 28x - 7x^2 = a + b(x + c)^2$$

where a , b and c are integers.

Find the value of a , the value of b and the value of c .

$a = \dots\dots\dots b = \dots\dots\dots c = \dots\dots\dots$

(Total for Question 14 is 3 marks)

DO NOT WRITE IN THIS AREA

DO NOT WRITE IN THIS AREA

DO NOT WRITE IN THIS AREA



DO NOT WRITE IN THIS AREA

DO NOT WRITE IN THIS AREA

DO NOT WRITE IN THIS AREA

15 Solve the inequality $6x^2 + 5x - 25 > 0$
Show clear algebraic working.

.....

(Total for Question 15 is 3 marks)

16 (a) Simplify fully $\frac{12x^{12}y^3}{6x^4y}$

.....

(2)

(b) Simplify fully $(2a^5b^3)^4$

.....

(2)

(Total for Question 16 is 4 marks)



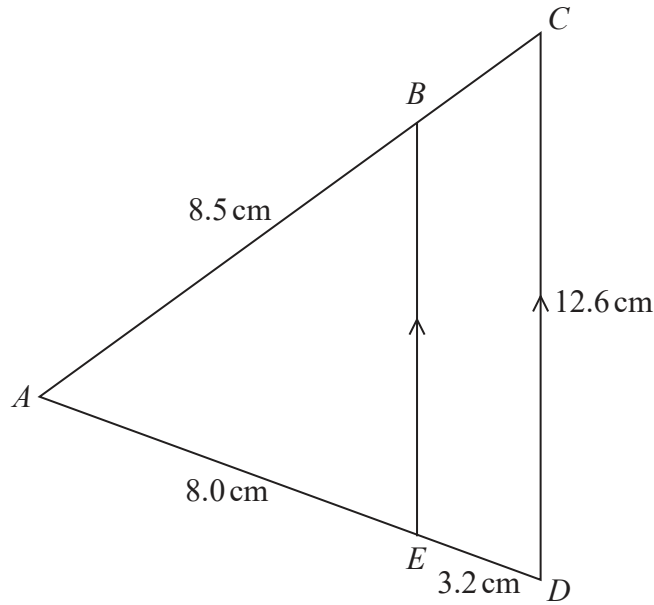

Diagram **NOT** accurately drawn

In the diagram, ACD is a triangle with point B on AC and point E on AD such that EB is parallel to DC .

$AB = 8.5 \text{ cm}$ $AE = 8.0 \text{ cm}$ $ED = 3.2 \text{ cm}$ $DC = 12.6 \text{ cm}$

(a) Calculate the length of EB .

..... cm
(2)

(b) Calculate the length of AC .

..... cm
(2)

(Total for Question 17 is 4 marks)

DO NOT WRITE IN THIS AREA

DO NOT WRITE IN THIS AREA

DO NOT WRITE IN THIS AREA



DO NOT WRITE IN THIS AREA

DO NOT WRITE IN THIS AREA

DO NOT WRITE IN THIS AREA

18

$$\mathbf{A} = \begin{pmatrix} 3 & 4 \\ p & 2 \end{pmatrix} \quad \mathbf{B} = \begin{pmatrix} 4 & 2p \\ 2q & -3 \end{pmatrix}$$

Given that $3\mathbf{A} + 2\mathbf{B} = \begin{pmatrix} 17 & 4 \\ -7 & 0 \end{pmatrix}$

find the value of p and the value of q .

$p = \dots\dots\dots$

$q = \dots\dots\dots$

(Total for Question 18 is 4 marks)



19 Solve the simultaneous equations

$$\begin{aligned}3x + 2y &= -1 \\4x - 3y &= -5.3\end{aligned}$$

Show clear algebraic working.

$$x = \dots\dots\dots$$

$$y = \dots\dots\dots$$

(Total for Question 19 is 4 marks)

DO NOT WRITE IN THIS AREA

DO NOT WRITE IN THIS AREA

DO NOT WRITE IN THIS AREA



Diagram **NOT**
accurately drawn

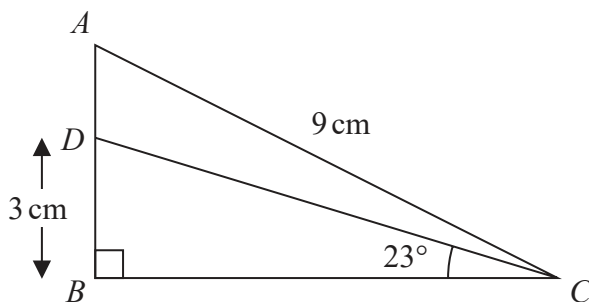

The diagram shows the right angled triangle ABC where $\angle ABC$ is 90° and $AC = 9$ cm.
The point D lies on AB such that $BD = 3$ cm and $\angle BCD = 23^\circ$

Calculate the size, in degrees to one decimal place, of $\angle ACD$.

.....
(Total for Question 20 is 4 marks)



21 Given that $a = -5$

(a) find the value of $\frac{2 - 2a}{3} + 2a^2$

.....
(2)

(b) Write $\frac{\sqrt[3]{c}}{c^2}$ in the form c^x where x is a rational number.

.....
(2)

(Total for Question 21 is 4 marks)



DO NOT WRITE IN THIS AREA

DO NOT WRITE IN THIS AREA

DO NOT WRITE IN THIS AREA

22 Solid A and solid B are similar.

The table gives information about the surface areas and the volumes of A and B .

	Surface area (in cm^2)	Volume (in cm^3)
Solid A	425	312.5
Solid B	x	67.5

Calculate the value of x .

$x = \dots\dots\dots$

(Total for Question 22 is 4 marks)



23 Ameer drove from his home to a business meeting.

The distance that Ameer drove was 210 km, to the nearest 10 km.

The time that he took was 3 hours 25 minutes, to the nearest 5 minutes.

Calculate the upper bound, in km/h to one decimal place, of Ameer's average speed as he drove from his home to the business meeting.

..... km/h

(Total for Question 23 is 4 marks)

DO NOT WRITE IN THIS AREA

DO NOT WRITE IN THIS AREA

DO NOT WRITE IN THIS AREA



DO NOT WRITE IN THIS AREA

DO NOT WRITE IN THIS AREA

DO NOT WRITE IN THIS AREA

24 Express $\left(\frac{3}{2x-4} - \frac{4}{x+2}\right) \div \frac{66-15x}{6x^2-4x-16}$ as a single fraction in its simplest form.

Show clear algebraic working.

.....
(Total for Question 24 is 4 marks)



25 Garcia makes bags from fabric.

Garcia buys a length of fabric that is 40 metres long.

The cost of the fabric is \$5 per metre and he uses all the fabric to make bags.

Each bag that he makes uses a length of 80 cm of the fabric.

Garcia sells $\frac{3}{5}$ of the bags he made for \$14 each bag.

He then reduces the selling price of each bag by 15% and sells the rest of the bags he made.

Calculate the percentage profit that Garcia makes by selling all the bags he made.

..... %

(Total for Question 25 is 5 marks)



DO NOT WRITE IN THIS AREA

DO NOT WRITE IN THIS AREA

DO NOT WRITE IN THIS AREA

26 Neeta is going to play one game of chess and one game of snooker.

The probability that she will win the game of chess is 0.35

The probability that she will win the game of snooker is 0.48

The two events are independent.

(a) Complete the probability tree diagram.

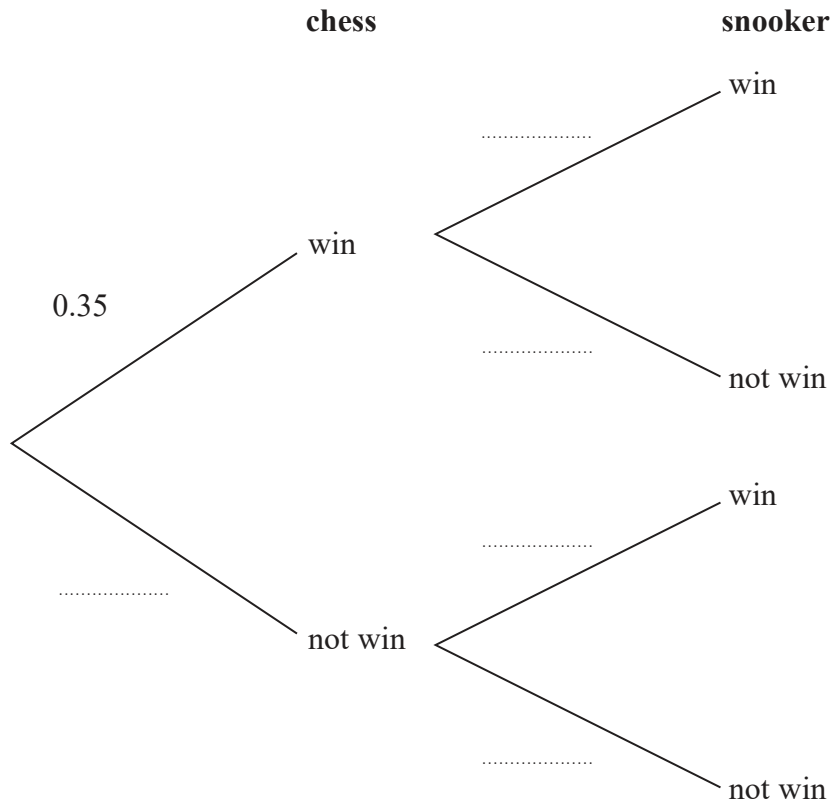

(2)

(b) Find the probability that Neeta will win only one of the games.

(3)

(Total for Question 26 is 5 marks)



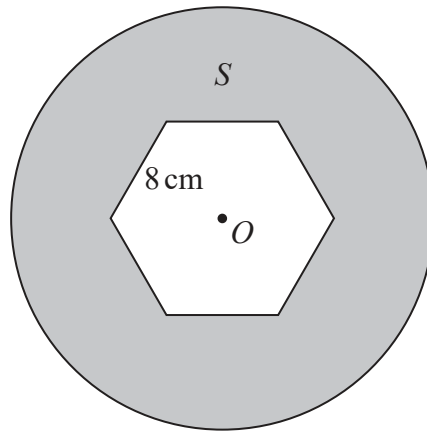

Diagram **NOT**
accurately drawn

The diagram shows a shaded region, S , formed by removing a regular hexagon from a circle.

The centre of the circle is the point O .

The hexagon has centre O and sides of length 8 cm.

Given that

$$\text{area of the hexagon} = \text{area of } S$$

calculate the radius, in cm to one decimal place, of the circle.



DO NOT WRITE IN THIS AREA

DO NOT WRITE IN THIS AREA

DO NOT WRITE IN THIS AREA

..... cm

(Total for Question 27 is 5 marks)

Turn over for Question 28



- 28 A bag contains n beads.
There are 4 orange beads in the bag.
The rest of the beads are purple.

Donald is going to take at random 2 beads from the bag.

The probability that both beads will be the same colour is $\frac{51}{91}$

Find the value of n .

Show clear algebraic working.

DO NOT WRITE IN THIS AREA

DO NOT WRITE IN THIS AREA

DO NOT WRITE IN THIS AREA



DO NOT WRITE IN THIS AREA

DO NOT WRITE IN THIS AREA

DO NOT WRITE IN THIS AREA

$n = \dots\dots\dots$

(Total for Question 28 is 6 marks)

Turn over for Question 29



29 A curve has equation $y = x^3 - 4x^2 + 5x + 3$

P and Q are two points on the curve.

P is the point with coordinates $(2, 5)$

The gradient of the tangent to the curve at P is equal to the gradient of the tangent to the curve at Q .

Find the exact coordinates of Q .

(.....,))

(Total for Question 29 is 5 marks)

TOTAL FOR PAPER IS 100 MARKS

DO NOT WRITE IN THIS AREA

DO NOT WRITE IN THIS AREA

DO NOT WRITE IN THIS AREA

